



LW15



LW25



LW45

# VENTA 空气均衡器 使用说明书

**VENTA LUFTWÄSCHER**

加湿洁净一体化

**GA SALES & SERVICES SDN BHD**

NO. 27, JALAN PP 11/4, ALAM PERDANA INDUSTRIAL PARK,  
TAMAN PUTRA PERDANA, 47130 PUCHONG,  
SELANGOR, MALAYSIA

WHATSAPP: +6012-908-7334

EMAIL: VENTAMY@GASALES.COM.MY

WWW.GASALES.COM.MY

# venta

RAUMLUFTEXPERTEN SEIT 1981



MADE IN GERMANY  
PREMIUM QUALITÄT



## 目录

安全提示	2
独特的作用方式	3
包装清单	3
机器描述	3
首次使用说明	5
设备启用	5
技术数据	7
质量保证	7
自动关闭	7
排除故障	7
有关废物处理的说明	7

## 安全提示

- 请在使用前，详细阅读本使用说明书，并将本说明书妥善保存，以备日后查阅。
- 只允许将本机插入适合的电源插座中 — 电源电压应符合本机铭牌中的给定规格。
- 只允许使用随附的电源接插器（型号“BI13-240050...”）来运行本机。
- 每次进行清洁或维护工作前，或需要搬运本机时，应从插座中拔出电源接插器。
- 若电源线或电源接插器损坏，切勿将本机投入使用。
- 若本机掉落或以其它方式损坏，切勿投入使用。
- 只允许由专业人员进行电气设备维修工作，维修操作不当会给用户带来严重危险。
- 切勿坐在本机上，也不得在其上放置物品。
- 不得将任何异物插入本机中。
- 本机并非为生理/感官功能受限人士、智障人士、或缺乏机器操作经验/知识人士（包括儿童）而设计，此类人士如需使用本机，必须要有安全监护人员在旁监督或指导。应看管好儿童，以确保他们不将本机当作玩具玩耍。
- 切勿将机器的上部浸入水中或其他液体里。
- 切勿拉扯以拔出电源线，或用潮湿的手将电源线从插座中拔出。
- 只有在本机完全组装好的状态下，方可投入使用。
- 必须将本机，放置在一个稳定、平坦和干燥的平面上。
- 本机必须与其他物体（如：家具、墙面等），保持至少50厘米的距离。
- 放置本机时，需注意避免其受到碰撞，且确保无人会被本机或其电源线绊倒。
- 不使用本机时，必须从插座中拔出电源接插器。
- Venta Airwasher 空气均衡器，只用于对居家、办公室和休闲空间的空气加湿及净化。切勿把本机用于其它目的，以免由于错误使用，引起危险或者伤害。制造商对因错误使用或使用不当而导致的人身伤害或财产损失概不负责。

特别强调：不允许将本机器用于以下场所：

- 有爆炸危险的房间里
- 腐蚀性环境里
- 高溶剂浓度的房间里
- 灰尘极大的房间里
- 游泳池或潮湿区域的附近

## 特别提示

只允许将原厂的专用 Venta 添加剂加入水中, 请勿加入非原厂添加剂。因为外来添加剂的不明成分, 可能会严重损坏本机。对因使用外来添加剂造成的损失, 本公司恕不承担任何责任。

## 尊敬的用户!

Venta System for Airwashing 向全球提供一种独特的空气清洗净化技术。Venta Airwasher (空气均衡器) 无需滤垫, 极其卫生。

## 独特的作用方式:

质量差的干燥空气被导入本机中。旋转的百叶片轮 (按不同型号, 面积 达至1.4 -9.7平方米), 确保干燥空气被充分加湿, 并挥发出纯净的水分子。小至10微米 (10/1000毫米)的微小颗粒, 也会被拦阻保留在水中。本机并不使用会随使用时间而变得肮脏的滤垫。Venta 的滤垫就是水: 每日新鲜的水, 日复一日、年复一年, 为您不变的、高品质的洁净和加湿空气。

## 包装清单

1台空气清洗器

1瓶 Venta 卫生剂 (50毫升/瓶) - 每瓶 Venta 卫生剂可以使用2周 (见第5页: 维护与清洁)

1份使用说明书

1份产品推广小册子、常见问题和香薰推广小册子

## 机器描述

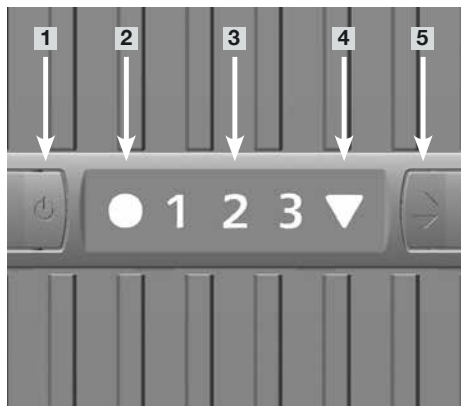
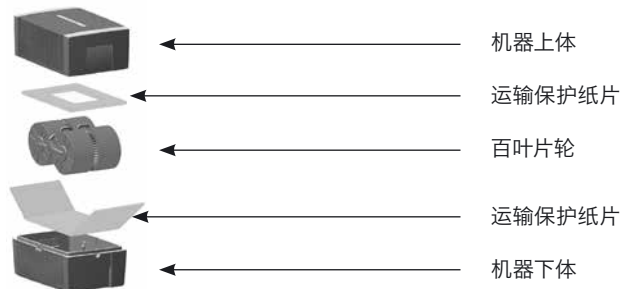

1 "开/关" 键

2 "开/关" 运行指示灯

长亮: 接通

不亮: 关闭

闪烁: 故障

(参见章节 "排除故障")

3 "风速等级" 显示: 1-2 (适用于LW15);  
1-2-3 (适用于 LW25/45)

4 "自动关闭" 显示  
(参见章节 "自动关闭")

5 "风速等级" 选择键 1-2 (适用于LW15);  
1-2-3 (适用于 LW25/45)

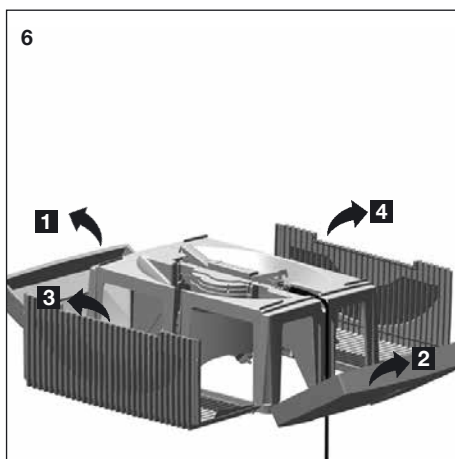
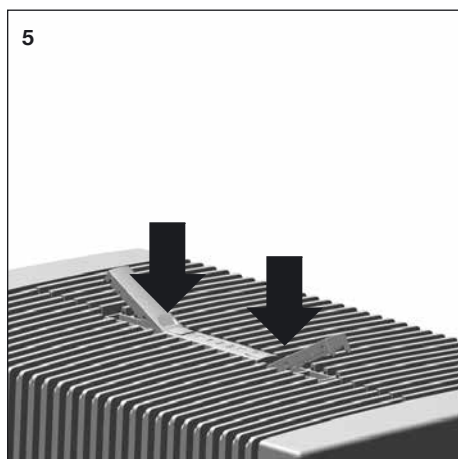
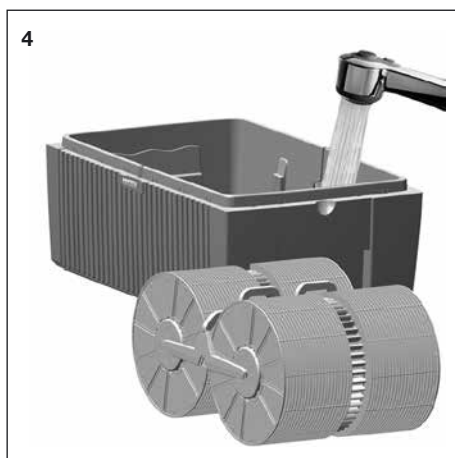
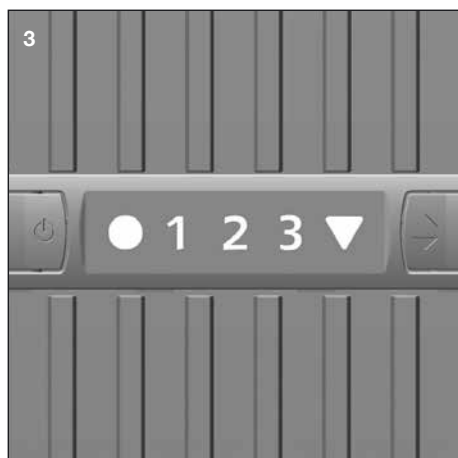
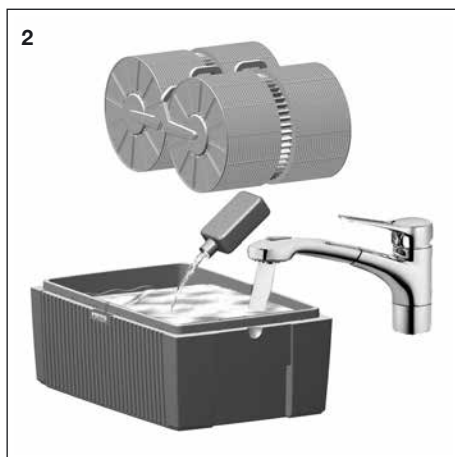
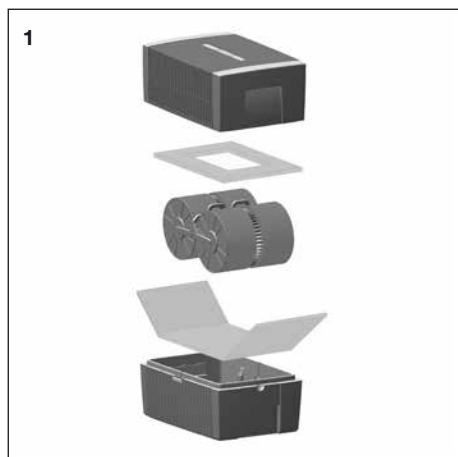

## 首次使用说明

请从泡沫塑料包装里取出 Venta 卫生剂。

**图1:** 取下机器上部。取出机器上部里的运输保护纸片。取出百叶片轮。拆除取出机器下部中的运输保护纸片。

## 设备启用

- 将本机放置在一个平坦干燥的平面，请注意本机与墙面、家具或其它物品应保持至少50厘米的距离。
- 请检查电源接插器及电源线是否完好无损。

**图2:** 取下机器上部，将水注入机器下部。切勿在机器上部没有移除的情况下，对机器下部进行加水！加入随附的一瓶 Venta 卫生剂（50毫升/瓶）。重新放入百叶片轮。

**图3:** 装上机器上部。将本机与电源连接。按键 **1** 启动机器 — 运行指示灯 **2** 亮起。用选择钮 **5** 选择想要的风速等级：1-2-3（适用于 LW25/45）；1-2（适用于LW15）。

## 维护与清洁

在进行各项清洁与维护工作前，必须从插座中拔出电源线！

### 日常操作 - 每天

按键 **1** 关闭本机，再从插座拔出电源接插器。取出机器上部，将新鲜水注入机器下部。装入机器上部。按键 **1** 启动机器。

### 正常维护 - 每隔10到14天

**图4:** 关闭本机，再从插座中拔出电源接插器。倒出污水。刷洗机器下部里的沉积物。随后用清水冲洗百叶片轮。给机器下部重新注入新鲜水。加入 Venta 卫生剂（见以下 'Venta 添加剂'）。剂量参见瓶背面的刻度线。

机器下部里及百叶片轮上的残余物（白色、黄绿色或褐色沉积物）并不影响 Venta Airwasher（空气均衡器）的功能。通过加入专用 Venta 卫生剂，可确保本机的运作洁净卫生。

### 定期清洁 - 每半年

我们建议您每隔半年使用 Venta 清洁剂对本机进行一次彻底清洁。根据空气均衡器受污染的严重程度，清洁时可能会产生异味。在此情况下，应确保室内的新鲜空气流通，Venta 清洁剂是专为 Venta 塑料件研发的，不会对本机产生腐蚀作用。请按照瓶上的使用说明使用。

## “机器上部”的清洁

**图5** 关闭本机，从插座中拔出电源接插器。通过按压锁定键（见箭头）打开机器上部。

**图6** 打开 机器上部请务必注意顺序：首先略微用力将两个侧面 **1** + **2** 翻开，随后将两个加筋叶片 **3** + **4** 朝外翻开。注意：请轻力小心打开侧面和加筋叶片，以免折断侧面和加筋叶片的结合处。

## VENTA 添加剂

LW 15 = 适用于 LW 14 的剂量，LW 25 = 适用于 LW 24，LW 45 = 适用于 LW 44。参见瓶背面的标注。

- Venta 卫生剂：可以抑制细菌生长，清除异味，软化水质、防止水垢，同时调节水膜的表面张力，使水膜均匀附着在百叶片轮的每个叶片表面，以促进气化过程，增强本机的加湿净化效果，并保护百叶片轮不受潮损坏。Venta 卫生剂不会随水分子蒸发，每天只需加入干净新鲜的水，便会激活Venta 卫生剂的功效。每隔14天，请彻底倾倒入本机的过滤水，清理底部残渣，然后更换新鲜水，再加入的Venta 卫生剂（剂量参见瓶背面的标注）。本机便可以发挥最佳的加湿净化效果。
- Venta 清洁剂：是为清洗 Venta 空气均衡器而特别配方制造的。我们建议您6个月清洗本机一次，或是在长期不用前进行一次彻底清洗，以保证机器内所有的污物都被清洗掉。注意：如不慎溅入眼睛，请立刻用清水冲洗。请存放在儿童触摸不到的地方
- Venta 香薰系列（可自选）：为 Venta 空气均衡器特别配制。100%的纯天然精油制造，有3种不同的香味：1. 甜橙香薰（提神醒脑，气味恬静）2. 桉叶油香薰（含有桉叶油成分，在感冒季节可以舒缓症状）3. 放松香薰（帮助您舒缓一天的疲惫，使您心情舒畅）。

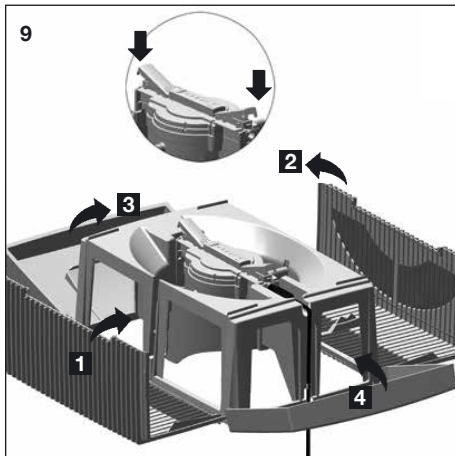
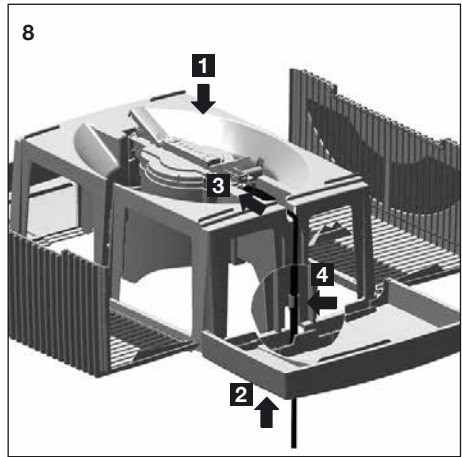
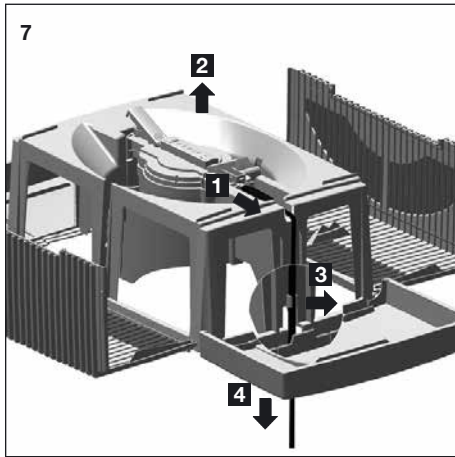

**图7** 从驱动单元将电源线插头拔出。然后将驱动单元往上拔出。从支架取出电源线并然后穿过机器上体洞孔向下拉出。

- 切勿拆开驱动单元和电源连接器，也不得将其浸入水中或与液体接触！
- 用干布擦净驱动单元、风扇叶片及变速机构。
- 将分拆的机器上体置于自来水下清洗。
- 在装配前必须彻底擦干已拆开的机器上体。

**图8** 将驱动单元方向正确地装入机器上体。将电源连接器从下穿过机器上体洞孔往上拉引并然后插入驱动单元且直至啮合止。最后将电源线卡入支架内。

**图9** 关闭上部时请务必注意顺序：锁定键的外端必须朝上。将两个加筋叶片 **1** + **2** 向上翻折，随后通过锁定键锁闭。同时按压锁定键的外端（见圆圈）。随后将两个侧面 **3** + **4** 往上盖合并然后锁紧。

## 技术数据

产品名称	LW 15	LW 25	LW 45
加湿能力, 房间规格*	至20平米	至40平米	至75平米
清洁能力, 房间规格*	至10平米	至20平米	至40平米
电压	100-240伏/50-60赫兹		
百叶片轮 - 片面积	1.4平米	2.1平米	4.2平米
风速选择	2	3	3
噪音水平	22/32分贝	24/34/44分贝	24/35/45分贝
尺寸	26 x 28 x 31厘米	30 x 30 x 33厘米	45 x 30 x 33厘米
重量	约3千克	约3.8千克	约5.8千克
功率 (风速档级1-2-3)	约 3-4瓦特	约 3-5-8瓦特	约 3-5-8瓦特
水箱容量	5 升	7 升	10 升
保修期	2 年	2 年	2 年
特低电耗			

\* 相关的房间高度上限 2.5米

## 质量保证

Venta Airwasher 有限公司提供两年的质量保证。本质量保证仅适用于在本机的购买国执行。请妥善保管购货发票, 以便维修时验证。

## 自动关闭

本机拥有“自动关闭”功能, 通过指示灯 **4** 发出信号。

出现以下情形时, 机器自动关闭:	怎么办
机器下体中的水位太低	关闭本机, 从插座中拔出电源接插器。加入新鲜水, 然后按“开/关”键重启。请参见章节“维护与清洁”-“日常操作”
机器上体被打开/没有锁紧	通过按压锁定键的外端部重新合上机器上体。按“开/关”键关机, 然后重启
机器上体未装上或未与机器下体正确接合	将机器上体安装到机器下体上。按“开/关”键关机, 然后重启

## 排除故障

故障	可能原因	怎么办
本机不能启动	1. 没有正确接上电源 2. 电源插头未插入驱动单元或者未能稳固啮合	1. 将电源接插器正确插入插座, 按“开/关”键启动本机 2. 将电源插头正确插入驱动单元, 并确保稳固啮合
“开/关”运行指示灯闪烁	马达/变速机构功能失灵	请与 马来西亚总部 取得联系: WhatsApp: +6012-908-7334

## 有关废物处理的说明



欧盟地区规定: 废弃的老旧电器和电子产品不可与家居垃圾一起处理。请使用当地的回收和收集

设施。感谢您对环境保护和人类健康作出的贡献。



## TABLE OF CONTENTS

Notes on safety -----	8
Unique functionality -----	9
Scope of delivery -----	9
Description of the appliance -----	9
Before first use -----	10
Putting into operation -----	10
Maintenance and cleaning -----	10
Technical data -----	14
Guarantee -----	14
Automatic shut-off -----	14
Eliminating faults -----	14
Waste disposal reference -----	14

## NOTES ON SAFETY

- Before putting the appliance into operation, please read these instructions carefully and keep them in a safe place for future reference.
- The Venta Airwasher is a domestic appliance for moistening and cleansing the air in homes, offices and leisure facilities. Using the appliance for something other than the intended purpose can endanger health and lives.
- The manufacturer is not liable for personal injury or damage to property brought about by careless or improper use.
- In particular, the appliance must not be used in the following circumstances:
  - in rooms or locations where there is risk of explosion;
  - in rooms where there is an aggressive atmosphere;
  - in rooms where there is a high concentration of solvents;
  - in rooms with considerable quantities of dust in the air;
  - in the vicinity of swimming pools or other wet areas.
- Plug the appliance into suitable power outlets only - the voltage must correspond to the details of the rating plate on the appliance.
- The Airwasher can only be operated with the "Model No. BI13-240050..." switching power supply (included).
- Never use the Airwasher if it has a damaged switching power supply or cable, or after it has malfunctioned or if it has been dropped or damaged in any other way.
- Repairs to electrical appliances should only be carried out by professional specialists. Amateur repairs could result in significant danger to the user.
- The appliance is not intended for use by people (including children) with restricted physical, tactile or mental abilities or experience and/or knowledge unless under the direct supervision of a person responsible for their safety, or have received instructions on the use of the appliance. Children should be supervised in order to ensure that they do not treat the appliance as a toy.
- Do not sit on the appliance and do not place any objects on it.



- Do not push any foreign objects into the appliance.
- Do not immerse the appliance in water or any other liquid.
- Never unplug the appliance by pulling on the cable or pulling the switching power supply out with wet hands.
- Unplug the appliance when it is not in use.
- Whenever the appliance is cleaned or serviced or repositioned it must first be unplugged from the socket.
- The Airwasher should only be operated when it is completely assembled.
- Place the Airwasher on a stable surface which is flat and dry.
- Ensure the appliance is at least 50cm from any objects such as furniture or walls.
- Place the appliance so that it cannot be knocked over, and so that no one can trip over it or its lead.
- Only add original Venta additives to the water. Venta-Luftwäscher GmbH accepts no liability for damage which may be caused by the use of other additives.

**DEAR CUSTOMER,**

The Venta system for Airwashing offers a technology unique in the world. The Venta Airwasher is designed without filter pads and is extremely hygienic.

**UNIQUE FUNCTIONALITY:**

Bad-quality, dry air is routed into the appliance. Rotating disk stacks with a surface area of up to 4.2m<sup>2</sup> guarantee, using the smallest space, that dry air is capable of absorbing moisture and pure water can evaporate. Dirt particles to 10µm (10/1000mm) are retained in the water. There are no filters which get dirty over time. The Venta filter is the water: Every day it is new and fresh and year for year it provides constant high-quality cleaning and humidification performance.

**SCOPE OF DELIVERY**

- 1x Airwasher
- 1x Hygiene agent sample package 50ml (sufficient for 2 weeks)
- 1x Operating instructions
- 1x Product brochure, questions & answers, fragrance brochure

**EQUIPMENT DESCRIPTION**

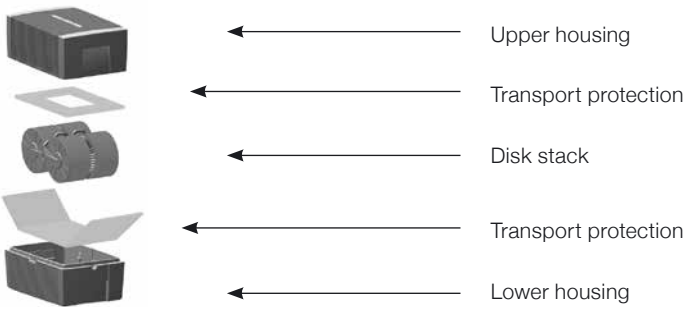

## OPERATOR PANEL

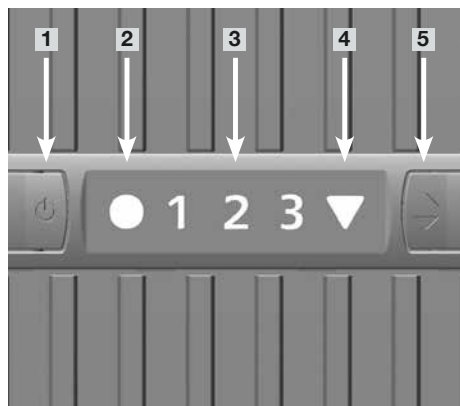

- 1** ON / OFF button
- 2** Operation indication ON / OFF  
Continuous lighting: ON  
No lighting: OFF  
Flashing: Fault  
(see Eliminating faults)
- 3** Fan stage display 1 - 2 (LW 15),  
1 - 2 - 3 (LW 25/45)
- 4** Automatic shut-off display  
(see "Automatic shut-off")
- 5** Fan stage selector button  
1 - 2 (LW 15), 1 - 2 - 3 (LW 25/45)

## BEFORE FIRST USE

Remove trial package from Styrofoam packaging.

**Illustration 1:** Remove upper housing. Remove transport protection from the upper housing. Remove disk stack. Remove transport protection from the lower housing.

## PUTTING INTO OPERATION

- Place the Airwasher on a dry and level surface at least 50cm from the walls, furniture and any other objects.
- Check whether switching power supply or cable are free from damage.

**Illustration 2:** Remove upper housing. Fill water into the lower housing. **The appliance may never be filled with the upper part in place!** Filling level: See marker in the lower housing (approx. 5cm below the trough rim). Add entire content of the Venta hygiene agent (sample bottle 50ml). Insert disk stack again.

**Illustration 3:** Replace the upper housing. Plug the appliance into the mains. Switch on the appliance with button **1** and operation display **2** lights up. Select required fan stage to 1 - 2 (LW 15), 1 - 2 - 3 (LW 25/45) with selector button **5**.

## MAINTENANCE AND CLEANING

**UNPLUG SWITCHING POWER SUPPLY IN CASE OF ALL CLEANING AND MAINTENANCE WORK!**

### DAILY

Switch off appliance with button **1** and unplug switching power supply. Remove upper housing and top up with fresh water into the lower housing. Mount top cover again. Switch on the appliance with button **1**.

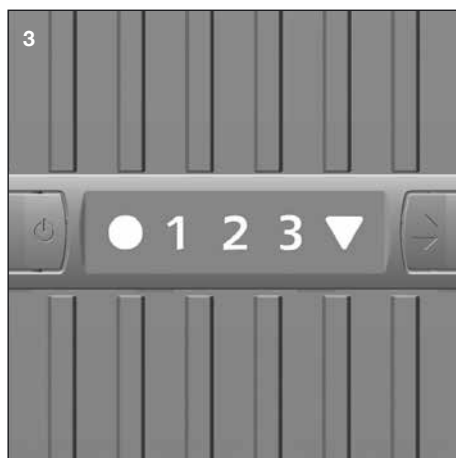
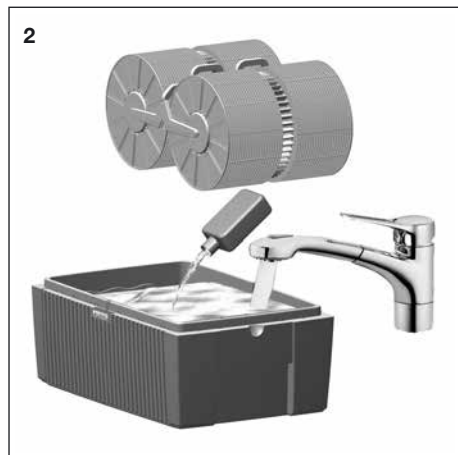
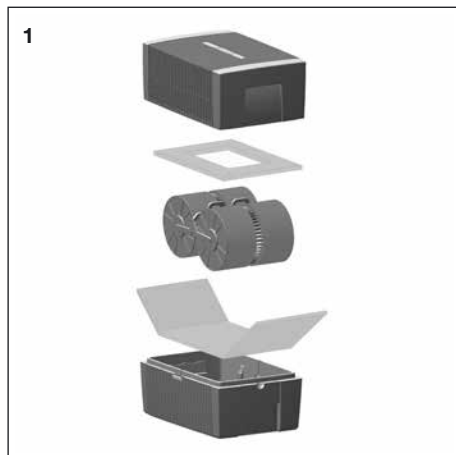

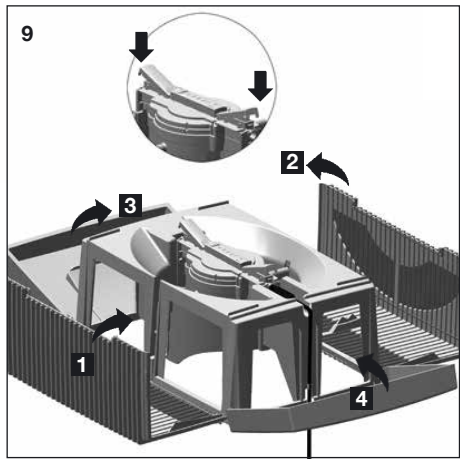
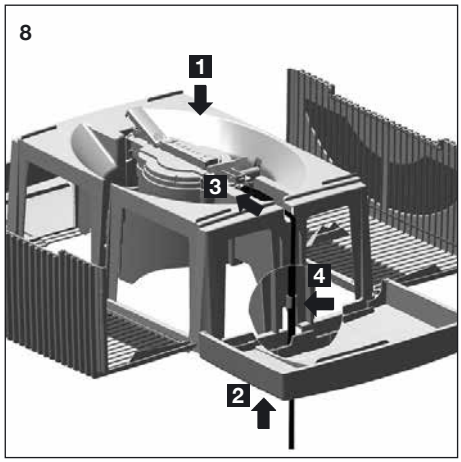
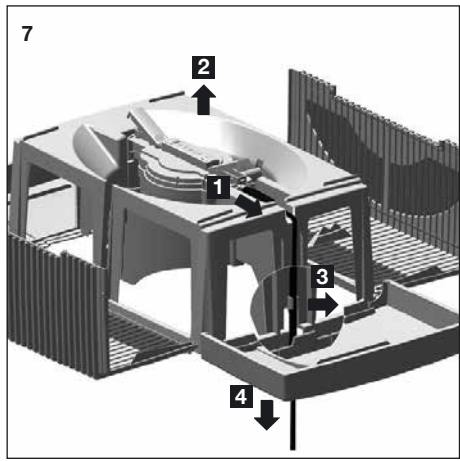
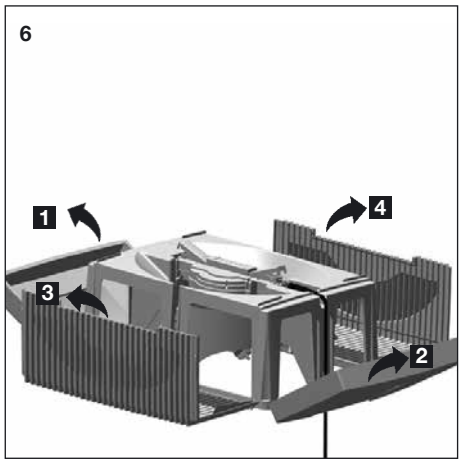
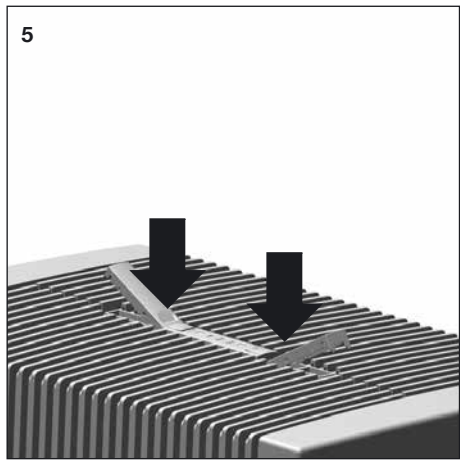
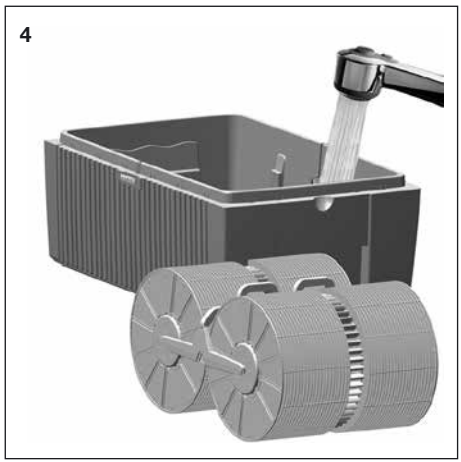

## EVERY 10-14 DAYS

**Illustration 4:** Switch off appliance and pull out switching power supply. Pour out soiled water. Brush off precipitated deposits in the lower housing and flush out. Flush disk stack with water. Fill lower housing with water again. Refill with Venta hygiene agent. For dosing, see scale on back of bottle.

*All residues in the lower housing and on the disk stack (white, green-yellowish or brownish precipitation) do NOT impair the function of the Venta Airwasher. As a result of the addition of the hygiene agent, trouble-free hygienic operation is guaranteed.*

### Dosage for models

LW 15 = Dosage for LW 14, LW 25 = Dosage for LW 24, LW 45 = Dosage for LW 44  
See back of the bottle.

## EVERY SIX MONTHS

We recommend a six-monthly general cleaning with the Venta Cleaner. According to the degree of pollution of the air washer, odors can possibly arise during cleaning. Please provide for fresh air ventilation in these cases. The Venta Cleaner was especially designed to be compatible with Venta plastics, without attacking them. Please consider directions for use on bottle.

## GENERAL CLEANING

**Illustration 5:** Switch off the appliance and pull out switching power supply. For the opening of the upper housing, press on the locking latch (see arrows).

**Illustration 6:** It is absolutely necessary to consider the sequence during the opening of the top cover: First pivot aside the two sides **1** + **2** (with light pressure) and after that pivot out the two ribbed wings **3** + **4**.

**Illustration 7:** Remove mains cable connector from drive unit **1**. Lift out drive unit **2**. Remove mains cable from holder **3** and pull out through opening in the upper housing **4**.

- Do not dismantle unit and switching power supply, do not immerse in water and do not bring into contact with liquid!
- Clean drive unit, fan blade and gearing with dry cloth!
- Dismantled upper housing can be cleaned under flowing water.
- Dismantled upper housing must be completely dry before assembly!!!

**Illustration 8:** Place drive unit into the upper housing in correct alignment **1**. Pull mains cable connector up from underneath through the opening of the upper housing **2** and plug into drive unit until latched **3**. Clip mains cable into holder **4**.

**Illustration 9:** For the closing of the upper housing it is absolutely necessary to follow the sequence: Place the external ends of the latches in the up position! First pivot up the two ribbed wings **1** + **2** and press on the external ends of the latches (see rings). After that pivot up the two side parts **3** + **4** and engage in latch.

## TECHNICAL DATA

PRODUCT DESIGNATION	LW 15	LW 25	LW 45
Humidifying capacity*	up to 20m <sup>2</sup>	up to 40m <sup>2</sup>	up to 75m <sup>2</sup>
Purifying capacity*	up to 10m <sup>2</sup>	up to 20m <sup>2</sup>	up to 40m <sup>2</sup>
Mains voltage	100-240V/50-60Hz	100-240V/50-60Hz	100-240V/50-60Hz
Disk surface	1,4m <sup>2</sup>	2,1m <sup>2</sup>	4,2m <sup>2</sup>
Speeds	2	3	3
Sound level	22/32dBA	24/34/44 dBA	24/35/45 dBA
Dimensions	26×28×31 cm	30×30×33 cm	45×30×33 cm
Weight	approx. 3kg	approx. 3,8kg	approx. 5,8kg
Motor output (Speed 1 - 2 - 3)	approx. 3-4 Watt	approx. 3-5-8 Watt	approx. 3-5-8 Watt
Water capacity	5 liter	7 liter	10 liter
Guarantee	2 years	2 years	2 years
Extremely low power consumption			

\* based on a ceiling height at a max of 2,5m

## GUARANTEE

Two years guarantee on defective parts and labour is given on your Venta Airwasher. The applicability is valid exclusively for the country in which the appliance was acquired. Proof of purchase provides guarantee verification.

## AUTOMATIC SHUT-OFF

The appliance has an automatic shut-off feature that is indicated by displaying **4**.

The appliance will shut off automatically if:	What to do
there is too little water in the lower housing.	Switch off appliance, disconnect switching power supply, top up with water and start operation again with button <b>1</b> . See also „Maintenance and cleaning“, „Daily“
the upper housing has been opened.	Close top cover again by pressing on the external ends of the latches. Switch the appliance on and off with button <b>1</b> .
the upper housing is not installed or is not properly fitted to the lower housing.	Place top cover onto lower container. Switch the appliance on and off with button <b>1</b> .

## ELIMINATING FAULTS

Problem	Possible causes	What to do
Appliance does not function	1. Switching power supply not connected. 2. Mains cable connector not plugged and latched into drive unit.	1. Connect switching power supply to mains socket, switch on appliance with button <b>1</b> . 2. Plug mains cable connector into drive unit until it latches.
Operation indication <b>2</b> flashes	Motor/Gearing malfunction	Please get in touch with Malaysia Headquarters WhatsApp: +6012-908-7334

## WASTE DISPOSAL REFERENCE



Valid for EU countries only: Old electrical and electronic appliances must not be disposed of in domestic waste. Please use the return and collection facilities available locally. In this way you can make a valuable contribution to environmental protection and to human health.





## GERMANY

Venta-Luftwäscher GmbH  
Weltestr. 5  
D-88250 Weingarten  
Tel.: +49 751 50 08 88  
Fax: +49 751 50 08 20  
service@venta-luftwaescher.de  
www.venta-luftwaescher.de

## SWITZERLAND

Venta-Luftwäscher AG  
Bösch 65  
CH-6331 Hünenberg  
Tel.: +41 41 781 15 15  
Fax: +41 41 781 15 50  
info@venta-luftwaescher.ch  
www.venta-luftwaescher.ch

## AUSTRIA

Venta-Austria GmbH  
Färbergasse 15  
6850 Dornbirn  
Tel.: +43 5572 202 539  
Fax.: +43 5572 202 537  
office@venta.at  
www.venta.at

## CZECH REPUBLIC

BODY COMFORT spol. s r.o.  
Velvarská 1  
CZ-25262-Horomerice  
Tel.: +420 724 020 444  
info@bodycomfort.biz  
www.prackyvzduchuventa.com

## CHINA

DDN GLOBAL SUPPLY CHAIN CO.,  
LTD.  
9th Floor A Unit Chengying  
Center, Laiguangying West  
Road, Chaoyang District, Beijing,  
Tel.: 400-181-6-181.  
Email: venta@ddn-global.com  
www.venta365.com

## HUNGARY

Distributed by  
Hungimpex Kft.  
Kunigunda útja 60.  
H-1037 Budapest  
Tel.: +36 1 453 71 00  
Fax: +36 1 453 71 01

## ITALIEN

Winkler Import GmbH | Srl  
Enzenbergweg 36, Via Enzenberg  
I-39018 Terlan | Terlano  
Tel.: +39 0471 633 053  
Fax: +39 0471 633 590  
info@winkler-import.it  
www.winkler-import.it

## BENELUX

Venta Benelux BV.  
Dorpstraat 113  
NL-5504 HC Veldhoven  
Tel.: +31 40 254 43 61  
Fax: +31 40 254 05 35  
info@venta.nl  
www.venta-airwasher.nl

## JAPAN

Venta Japan Corporation  
Blanche HORIE 7F, Minami-Horie  
1-14-12Nishi-Ku, Osaka Japan  
550-0015  
Phone: + 81 6 4301 7751  
Fax: + 81 6 4301 7754  
www.venta.co.jp

## KAZAKHSTAN

Venta Kazakhstan GmbH  
Baisakova Str. 222  
2te Stock  
Office 23  
050000 Almaty  
Tel.: +7 72 73 78 86 03  
Fax: +7 72 73 78 86 03  
E-Mail: office@venta.kz  
www.venta.kz

## LATVIA & LITHUANIA

Distributor: SIA „BALTIJAS  
TIRDZNICĪBAS UZŅĒMUMS”  
Dārzaugļu iela 1-201  
Rīga LV-1012, Latvia  
Tel.: +371 67790720  
info@btu.lv, www.btu.lv

## POLAND

Venta-Polen s.c.  
ul. Poznańska 37  
PL-93-134 Łódź  
Tel./Fax: +48 42 681 00 67  
www.venta-airwasher.pl

## ROMANIA

S.C. Life Art Distributie S.R.L.  
Bucuresti, Sector 6, Bdul. Timisoara  
Nr. 103-111, Stand D4-D5, Incinta  
Bucuresti-Construct  
Tel.: +4021.314.2144  
office@lifeart.ro  
www.umidificator-venta.ro

## USA

Venta Air Technologies Inc.  
US Headquarters  
300 N. Elizabeth St. Suite 220 B  
Chicago, IL 60607  
Tel.: +1 88 83 33 82 18  
Fax: +1 224 567 8349  
info@venta-usa.com  
www.venta-usa.com

## RUSSIA

TSK Import  
RUS-124683, Moskau  
Selenograd, 1505, Raum III  
Tel. + Fax: +7 499 733 10 10  
venta@venta.ru  
www.venta.ru

## SOUTH KOREA

Venta Korea Co., Ltd.  
3/F., Seojin Bldg., 754  
Seolleung-ro, Gangnam-Gu,  
Seoul 135-948, Korea  
Tel.: +82-2-2034-0114  
Fax: +82-2-2034-0119  
www.venta.co.kr

## SOUTH AFRICA

EUROCARE Wellness  
5 Star Business Park, Unit 2,  
Persimmon Close, Honeydew,  
Johannesburg  
Tel +27 (0) 11 888 3255  
Fax +27 (0) 11 888 9874  
info@eurocarewellness.co.za  
www.venta-airwasher.co.za

## SLOVAKIA

BODY COMFORT spol. s r.o.  
Floglova 4  
SK-81105-Bratislava  
Tel: +421 0903 630 681  
info@bodycomfort.biz  
www.prackyvzduchuventa.com

## UKRAINE

Venta-Centre Ukraine  
Schlichtera, 11  
UA-Kharkov  
Tel.: +38 057 752 72 72  
Fax: +38 057 768 01 57  
venta@online.ua  
www.venta.com.ua